



Data Power Monitoring Corporation

181 Third Street, Suite 150
San Rafael, California 94901
1.866.ASKDPMC 1.415.634.1661
www.dpmc.com

The Importance of Monitoring AC ripple Voltage and Current

Bart Cotton
Founder, DPMC
Working Group Chair
IEEE 1491 - Battery Monitoring
IEEE Standards Association - Stationary Batteries
<http://www.ewh.ieee.org/cmte/PES-SBC>



Executive Summary

In today's data reliant environment, no element can be overlooked in support of total systems working towards delivery 100% uptime. One of the growing concerns as it relates to power supply feeding strategic sources is how excess AC ripple voltage varies between DC voltage, for example 12.5 Volts and 13.5 Volts, and does so rapidly. An alternator producing electrical current through a magnetic field detects change in the strength of the magnetic field used to charge the battery or to run electrical current. This often undetected fluctuation can shorten the service life of batteries. This paper looks at why AC ripple occurs, where it occurs, and how through monitoring, load loss risk is minimized to avoid potentially serious collateral damage to the UPS.

Background

One of the major parameters that affect the service life of battery systems is ripple voltage and current. Among other parameters that can affect the health of battery systems include:

- Charge voltage
- Charge current
- Discharge events (frequency and duration of discharge)
- Temperature
- Internal ohmic values (ie.: impedance, resistance, conductance, etc.)
- Connection integrity
- Quality and Design of batteries
- UPS Design

Ripple levels vary depending on the type of battery application, listed below.

UPS (Uninterruptible Power Systems)	High ripple level
Telecommunication Systems	Low ripple level
Switchgear Systems (includes Utility applications)	Low ripple level
Engine Starting Systems	Low ripple level

Table A - Ripple Level by battery system application

Illustrated in Table A, UPS systems place the highest levels of ripple on batteries due to the noisy nature of the rectification and inversion process of UPS systems. Other system types such as Telecom equipment produce low levels of ripple. The presence of excessive ripple maybe an indication of a system malfunctioning.

In order to understand the nature of ripple generation, a brief tutorial is presented below on the difference between UPS and DC power systems:

UPS (Uninterruptible Power Systems)

UPS systems provide uninterrupted AC power for computer networks or servers. The UPS rectifier converts the Utility AC voltage to a DC voltage to charge the batteries and also feed the inverter. The inverter feeds an AC electrical load. See Figure 1.

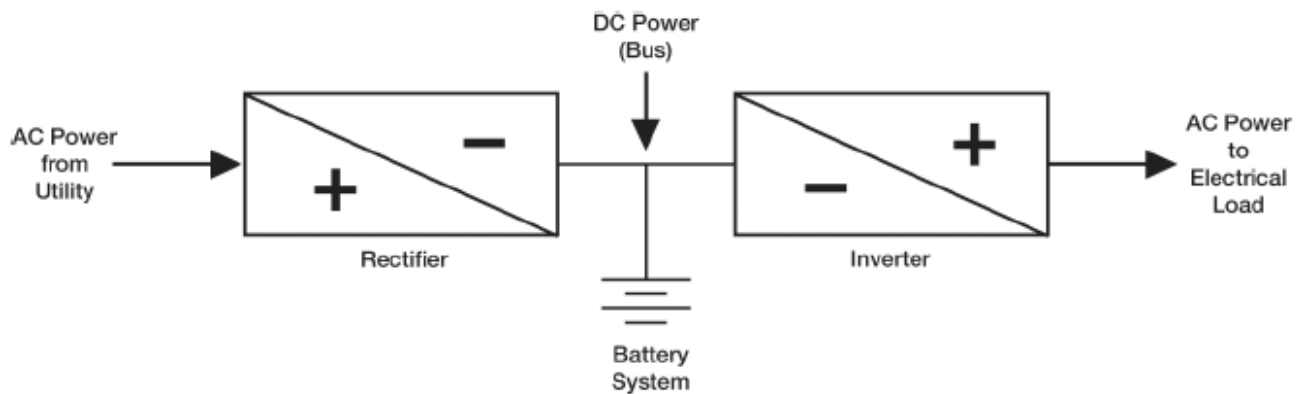

Figure 1: Typical UPS topology

Figure 2 illustrates how the output of a UPS system is a regenerated AC sine wave derived from a square wave (filtered). IGBTs turn on and off reproducing the sine wave. AC capacitors smooth out the sine wave.

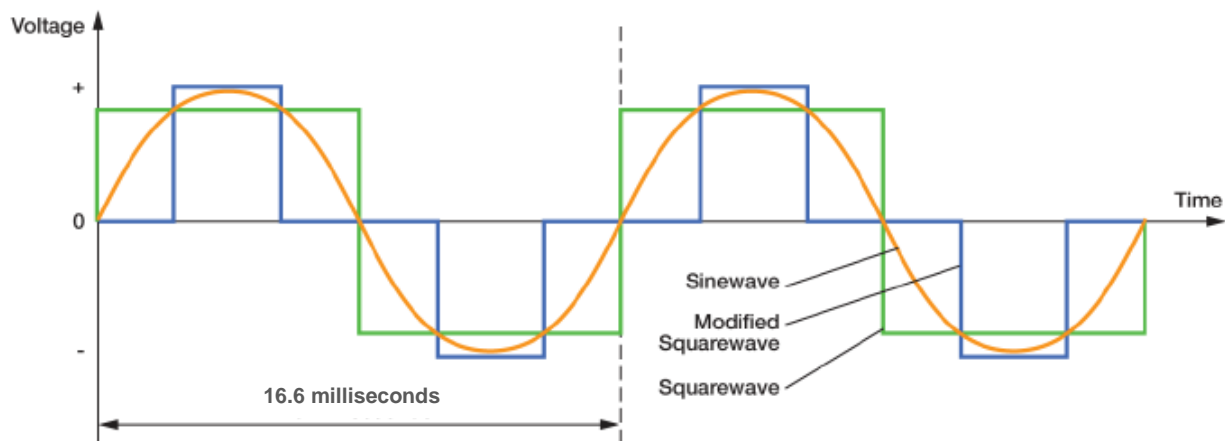

Figure 2: Inverter Output Sine wave

Figure 3 illustrates where AC ripple occurs as a byproduct of the rectification process, when converting AC voltage to DC voltage. AC ripple are the filtered remnants of the AC waveform riding over the top of the DC output voltage passing through a DC capacitor network.

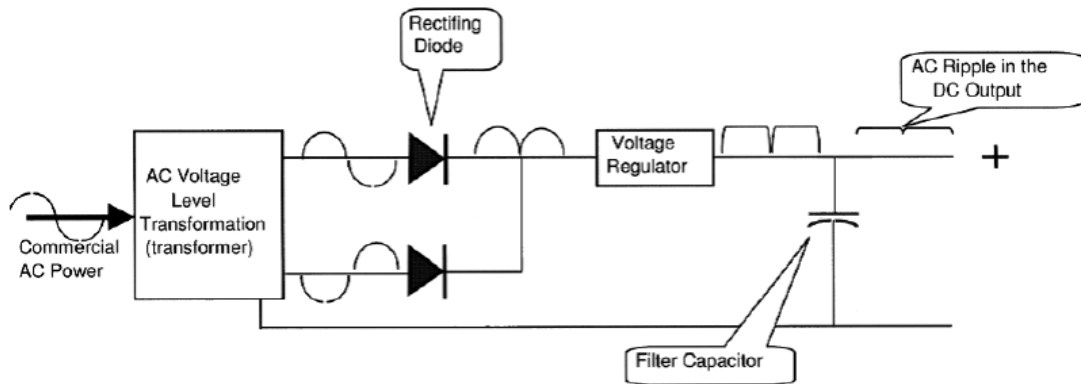

Figure 3: Rectification of AC voltage producing AC ripple

DC Power System

DC systems provide uninterrupted DC power for various DC type loads such as Telecom, Switchgear and Gensets. Rectifiers convert the Utility AC voltage to a DC voltage to charge the batteries which then feeds a DC electrical load.

Unlike a UPS, DC power systems such as Telecom equipment have far more filtering electronics for extensive ripple elimination. Telecom has a much cleaner DC voltage because it is directly tied to the load.

Figure 4 illustrates a DC power system being fed from the Utility Company that then feeds a DC electrical load without the need of an inverter, avoiding the presence of excess AC ripple. The electrical load obtains its DC power either from the rectifier, or in the case of power outages or disturbances from the battery system.

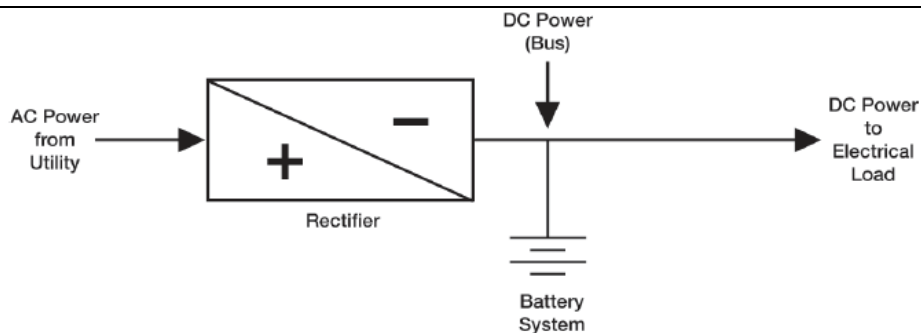

Figure 4: Typical DC Power System

Ripple Discussion and Definitions

Ripple is the AC component of a power system's charging voltage which is imposed on the DC bus or by the interaction of load equipment connected to the DC bus. The result is a ripple current flowing into the battery.

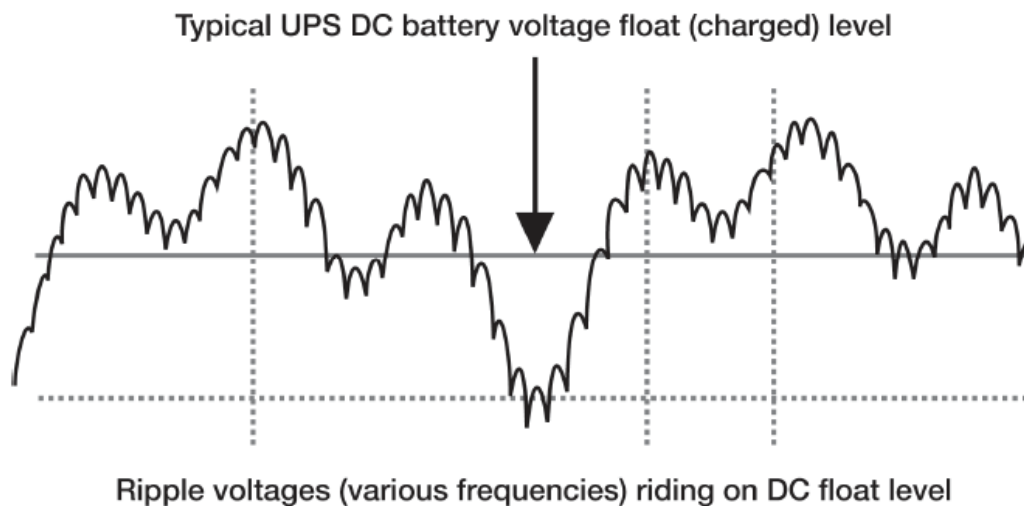

Figure 5: Typical Ripple voltage on a UPS DC bus

The amplitude of the ripple is primarily the result of the rectifier design, output filtering, and the type and magnitude of the load placed in parallel with the battery. All of these items contain varying degrees of ripple. The resulting ripple voltage and current imposed on a battery DC bus can have an adverse effect on the service life of a battery system and electronic equipment connected to the battery. Consequently, this ripple should be taken into consideration when monitoring a battery system.

In a typical telecommunications system, the rectifier/charger is heavily filtered and the load is such that there may not be any significant ripple voltage or current to measure. However, degradation of filter capacitors will cause an increase in ripple. Conversely, in typical UPS applications, there may be excess ripple imposed on the battery. Typically it occurs as a result of inadequate filtering of the rectifier/charger output voltage and low impedance and switching loads. Due to the nature of UPS operation, AC ripple will only be detected across a battery or across the DC bus.

Note: Referring to Figure 4 above, please note that ripple has a wide frequency spectrum. This is due to non-linear or harmonic effects. A harmonic is a multiple of a basic frequency. For example, if the basic frequency were say 60 Hz, the third harmonic would be 180 Hz, the



fifth, 300 Hz, and so on. Many harmonics are present in battery systems. Some refer to them as “noise”, but there is a difference between harmonics and “noise”.

The Importance of Monitoring

The purpose of monitoring ripple is to detect and prevent harmful levels of ripple voltage and current, from damaging the system’s electronics and/or damage to the battery system. The presence of AC ripple voltage leads to shallow discharge cycles producing hydrogen gas, sulfation on the battery plates and heat within the cell due to exothermic electrochemical reactions. As AC ripple voltage increases, AC ripple current rises. An increase of AC ripple current also adds to the internal heat generated inside the battery. Ultimately, excessive ripple current leads to excessive gassing, heat and dry-out, consequently diminishing the service life of the battery.

Excessive AC ripple voltage can also be indicative of failing capacitors that can potentially explode and cause collateral damage to personnel, UPS equipment and UPS load loss.

Indications and interpretations of monitored data are below:

- The limits typically imposed by battery manufacturers for VRLA batteries are:
 - A maximum ripple voltage of 0.5% of the float voltage.
 - A maximum ripple current of 5 Ampere per 100 Ah of rated battery capacity
- Most battery manufacturers specify the maximum permissible ripple only in the form of the permissible ripple voltage. However, the user should use this limit with caution, in that the resulting ripple current and resulting heating will be a function of the internal ohmic value of the battery. A lower ohmic value will result in higher ripple current, and a higher ohmic value will result in lower ripple current. The user should use this information with the understanding that although the battery may tolerate a certain degree of ripple voltage, the load may not. For instance, in telecommunication systems, the load may not tolerate a ripple voltage higher than 0.1%, whereas the battery might not be affected by a ripple voltage even five times greater.
- UPS manufacturers can provide a specification of the allowable AC ripple produced from their UPS system. The frequency of the ripple generated by the load and the rectifier/charger will vary depending upon the design of the rectifier/charger as well as the type of equipment being powered. In some UPS installations, the predominant ripple frequency will be a low multiple of 60 Hz; however, the spectrum might reach a few hundred kilohertz depending on system design. In telecommunication applications, even higher frequencies might be present. It is generally accepted that frequencies higher than 500 Hz will have little impact on the battery.
- Although excessive ripple can negatively impact the battery service life, a small amount of ripple can exist with no measurable impact and can even be incorporated into the



monitoring system as a “test” parameter. For example, when a small ripple voltage is applied to parallel strings of identical batteries, the same ripple current would be expected to flow through each string; if not, it may be an indication of an existing problem.

Conclusion

Excessive AC ripple voltage and current has been proven to be detrimental to the service life of battery systems. The damaging effects of AC ripple can be pre-empted with a comprehensive battery monitoring program that measures and trends AC ripple and therefore initiates the appropriate corrective measure. Additionally failing DC capacitors can also be detected preventing the cost of interruption from UPS load loss.

Related References

IEEE 1491 (*IEEE Guide for Selection and Use of Battery Monitoring Equipment in Stationary Applications*)

IEEE 1188 (*IEEE Recommended Practice for Maintenance, Testing, and Replacement of Valve-Regulated Lead-Acid (VRLA) Batteries for Stationary Applications*) -

Discussion is primarily for DC Power Systems and includes the following:

“A battery charger with low electrical noise levels must be used for VRLA batteries to limit the ripple current. Many manufacturers recommend the use of filtered battery chargers. An acceptable charger is one that does not raise the average fully charged battery operating temperature, as measured at the negative terminal, by more than 3 °C (5 °F) above ambient in a free-standing condition.”

IEEE 1184 (*IEEE Guide for Batteries for Uninterruptible Power Supply Systems*) –

Discussion follows:

“UPS applications can place unusual load conditions on a battery. Typically, UPS battery design seeks excellent short-term, high-rate current characteristics which in turn require the lowest possible internal cell resistance. This low resistance allows a lower impedance path for the ripple current coming out of the rectifier stage of the UPS than the filter capacitors in the output of the rectifier.”

“In addition, the inverter stage of the UPS requires large instantaneous dc currents as it builds ac power from the parallel rectifier/battery combination. With a high impedance ac power source, short-term, instantaneous load current changes will be drawn from

the lower impedance battery. These factors may result in a relatively high ac component in the battery. At present, manufacturers place no warranty penalties on vented cells operated in a high ripple current environment. However, ripple is an important consideration in effecting design life and it is advisable to maintain the rectifier filters as prescribed by the manufacturer.”

“Note: Ripple currents can cause overheating in VRLA batteries.”



Intelec 2005 – *Benefits Of A Battery System Ventilation Check List* by Bruce H. Dick Battery Associates, Stephen W. McCluer, American Power Conversion
Discussion follows:

“Does the charging system meet battery requirements for AC ripple voltage/current?”

A somewhat less obvious but equally detrimental failure would be that of the output filtering of the battery float charger. Even though the AC ripple voltage output of the charger may be quite low (less than 0.5%rms of the float voltage), the internal resistance of the battery being charged could also be extremely low and a significant AC ripple current can flow through the battery. The AC ripple current from the charger could be several amperes and could cause additional heating of the battery.

If AC ripple output voltage of the charger exceeds 4% peak-to-peak of the float voltage, this could result in actual "cycling" of the battery and a resulting additional rapid rise in temperature, DC float current, gassing etc. To prevent heating of the battery due to AC ripple current, the AC ripple current should be limited to less than 5 amperes per 100 Ah of rated battery capacity. This requirement is common to most battery manufacturers operating instructions. The best way to assure this never becomes a problem for VRLA batteries is to ensure the charging systems have well filtered DC outputs.”

Intelec 2005 - *To Monitor Or Not; 'Tis The Question*, Curtis Ashton, Qwest

“Ripple Voltage and Current — monitorable with specialized equipment, and useful on UPS systems, but not for typical telecom DC plants because the ripple coming from the rectifiers is extremely low. “